

PROTECTION EQUIPMENT

Guard Rail

Features

- Ideal for preventing damage to expensive machinery, equipment, office walls, electrical boxes, water mains, mezzanines and most importantly personnel from forklifts and other mobile equipment
- Easy installation with hardware and floor anchors included
- Painted safety yellow for high visibility
- Designed, tested and rated to withstand 10,000 lbs. at 4 M.P.H.
- Simple layout with universal column design
- In stock for fast delivery (selected sizes)
- Columns are 5" x 5" steel square tubes mounted on 10" x 10" base plates
- Rails are formed from high tensile 10 gauge steel for impact strength
- Flange nuts are welded inside columns at each hole for ease of installation
- Optional offset and corner columns are available for tight fitting applications

Guard Rail Specification

To ensure proper protection consider the following:

- Measure overall length of area that is to be protected
- Is there a protruding object or other unusual configuration to measure? (*Going around corners*)
- Is this a single or double rail application? (*The height to protect is the key factor*)
- Place the guard rail a minimum of 12" in front of protected equipment

Laying Out Guard Rail

- When determining rail length use dimension "B" Center of Column to Center of Column. Lift-Out Adapters add 1" to each span of rail
- If the application is a very tight fit then you must measure from outside to outside of base plates (Dimension "C")

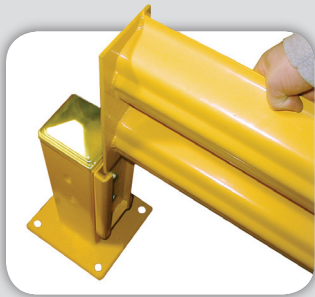

Lift-Out Adapters

When it is necessary to access equipment or space behind the guard rail system, lift-out adapters are available. These adapters use slot assemblies on the columns to allow the rails to be removed and then dropped back into place



Double Rail System



Single Rail System

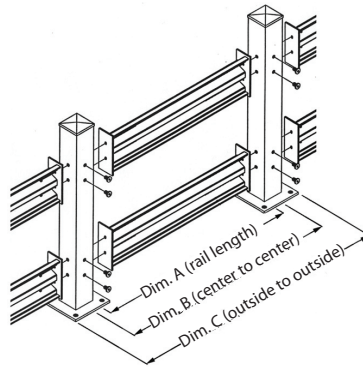

Guard Rail Dimension Information

Rail	Dim. A	Dim. B	Dim. C
GR-10	115"	120"	130"
GR-9	103"	108"	118"
GR-8	91"	96"	106"
GR-7	79"	84"	94"
GR-6	67"	72"	82"
GR-5	55"	60"	70"
GR-4	43"	48"	58"
GR-3	31"	36"	46"
GR-2	19"	24"	34"

Model Number	Description	Weight (lbs.)
Guard Rail		
GR-10	10' Rail	84
GR-9	9' Rail	76
GR-8	8' Rail	70
GR-7	7' Rail	62
GR-6	6' Rail	53
GR-5	5' Rail	43
GR-4	4' Rail	33
GR-3	3' Rail	24
GR-2	2' Rail	16
Guard Rail Columns		
CS-1	Single Rail Column	37
CS-2	Double Rail Column	58
CS-3	Triple Rail Column	58
Guard Rail Options		
LOA	Lift-Out Adapter (Pair)	10
AA-45	Angle Adapter	10
CSC-1	Single Rail Corner Column	37
CSO-1	Single Rail Offset Column	37
CSC-2	Double Rail Corner Column	58
CSO-2	Double Rail Offset Column	58
WA	Wedge Anchor	1

Note: Column price includes all assembly and anchoring hardware